

L:
 CBL-HFPD3SAB6MBS-1m 1000mm±10mm
 CBL-HFPD3SAB6MBS-2m 2000mm±20mm
 CBL-HFPD3SAB6MBS-3m 3000mm±20mm
 CBL-HFPD3SAB6MBS-4m 4000mm±30mm
 CBL-HFPD3SAB6MBS-5m 5000mm±30mm

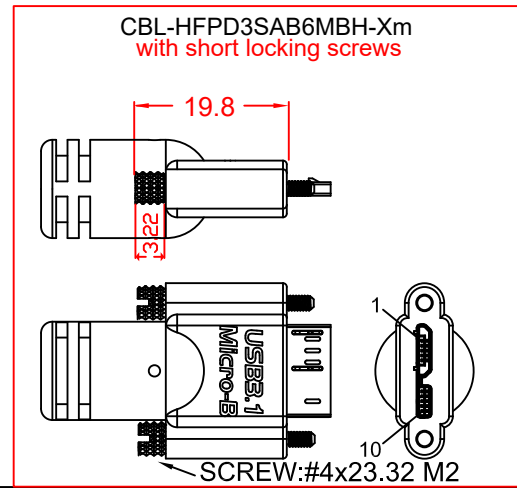

No	MATERIALS LIST:
1.	CABLE: 3 x (2 x 24 AWG)ST + 2 x 22 AWG O.D.:8.8mm COLOR:RED LILAC
2.	CONNECTOR:USB 3.0 A/M, 9P, BLUE INSULATOR SOLDER TYPE, NICKEL PLATED SHELL
3.	CONNECTOR:USB 3.0 MicroB/M, 10P, BLACK INSULATOR SOLDER TYPE, NICKEL PLATED SHELL
4.	PVC MOLDED HOUSING, BLACK COLOR
5.	SCREW:#4x33 M2

Jargy part no.	Client part no.	Approved	SCALE	UNIT
CBL-HFPD3SAB6MBS-xm				mm
Drawing Name		Drawn	Date	REV.
USB 3.0 A to MicroB Cable M/M				1.0

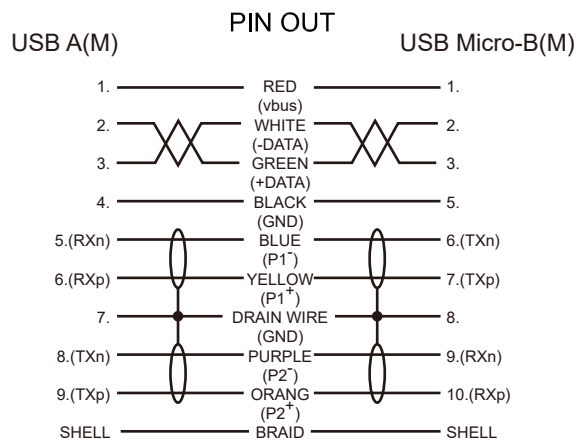
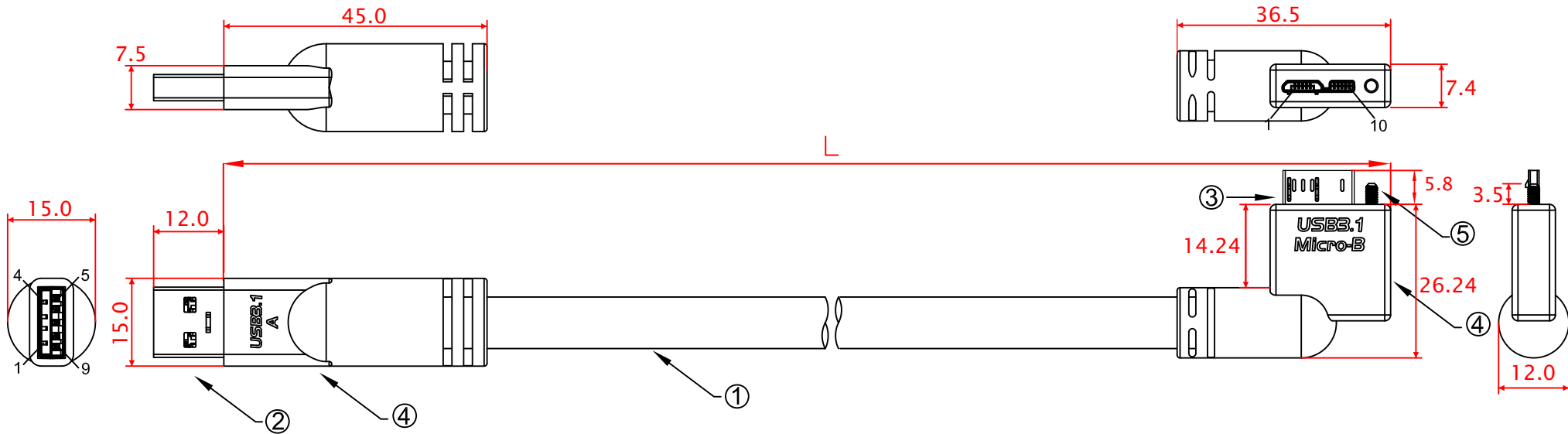

- L:
- CBL-HFPD3SAB6MBH-1mLA 1000mm±10mm
 - CBL-HFPD3SAB6MBH-2mLA 2000mm±20mm
 - CBL-HFPD3SAB6MBH-3mLA 3000mm±20mm
 - CBL-HFPD3SAB6MBH-4mLA 4000mm±30mm
 - CBL-HFPD3SAB6MBH-5mLA 5000mm±30mm

No	MATERIALS LIST:
1.	CABLE: 3 x (2 x 24 AWG)ST + 2 x 22 AWG O.D.:8.8mm COLOR:RED LILAC
2.	CONNECTOR:USB 3.0 A/M, 9P, BLUE INSULATOR SOLDER TYPE, NICKEL PLATED SHELL
3.	CONNECTOR:USB 3.0 MicroB/M, 10P, BLACK INSULATOR SOLDER TYPE, NICKEL PLATED SHELL
4.	PVC MOLDED HOUSING, BLACK COLOR
5.	SCREW:#4x23.32 M2

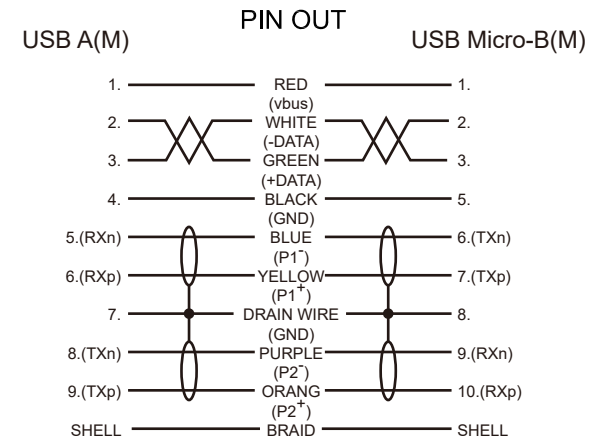

Jargy part no.	Client part no.	Approved	SCALE	UNIT
CBL-HFPD3SAB6MBH-xmLA				mm
Drawing Name		Drawn	Date	REV.
USB 3.0 A to MicroB Cable M/M				1.0

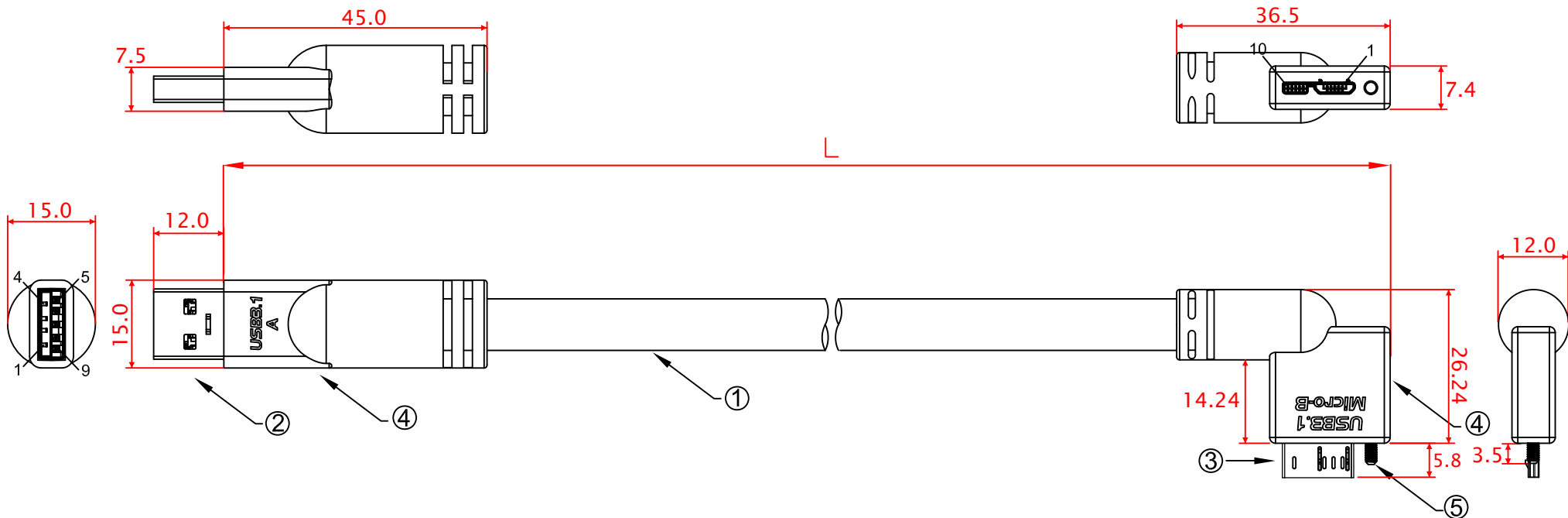

- L:
- CBL-HFPD3SAB6MBH-1mRA 1000mm±10mm
 - CBL-HFPD3SAB6MBH-2mRA 2000mm±20mm
 - CBL-HFPD3SAB6MBH-3mRA 3000mm±20mm
 - CBL-HFPD3SAB6MBH-4mRA 4000mm±30mm
 - CBL-HFPD3SAB6MBH-5mRA 5000mm±30mm

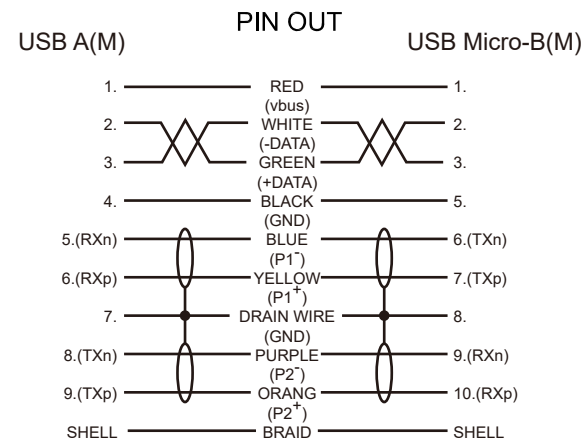

No	MATERIALS LIST:
1.	CABLE: 3 x (2 x 24 AWG)ST + 2 x 22 AWG O.D.:8.8mm COLOR:RED LILAC
2.	CONNECTOR:USB 3.0 A/M, 9P, BLUE INSULATOR SOLDER TYPE, NICKEL PLATED SHELL
3.	CONNECTOR:USB 3.0 MicroB/M, 10P, BLACK INSULATOR SOLDER TYPE, NICKEL PLATED SHELL
4.	PVC MOLDED HOUSING, BLACK COLOR
5.	SCREW:#4x23.32 M2

Jargy part no.	Client part no.	Approved	SCALE	UNIT
CBL-HFPD3SAB6MBH-xmRA				mm
Drawing Name		Drawn	Date	REV.
USB 3.0 A to MicroB Cable M/M				1.0